



**File Name:** camaras manuales nikon.pdf

**Size:** 3583 KB

**Type:** PDF, ePub, eBook

**Category:** Book

**Uploaded:** 25 May 2019, 14:58 PM

**Rating:** 4.6/5 from 764 votes.

**Status:** AVAILABLE

Last checked: 8 Minutes ago!

**In order to read or download camaras manuales nikon ebook, you need to create a FREE account.**

[\*\*Download Now!\*\*](#)

eBook includes PDF, ePub and Kindle version

[Register a free 1 month Trial Account.](#)

[Download as many books as you like \(Personal use\)](#)

[Cancel the membership at any time if not satisfied.](#)

[Join Over 80000 Happy Readers](#)

### Book Descriptions:

We have made it easy for you to find a PDF Ebooks without any digging. And by having access to our ebooks online or by storing it on your computer, you have convenient answers with camaras manuales nikon . To get started finding camaras manuales nikon , you are right to find our website which has a comprehensive collection of manuals listed.

Our library is the biggest of these that have literally hundreds of thousands of different products represented.



## Book Descriptions:

# camaras manuales nikon



Tambien te dejamos un enlace para descargarte la ultima version del firmware de tu camara NIKON. Captura nitidas texturas finas y proporciona imagenes limpias y nitidas. EXPEED 4A te permite capturar imagenes espectaculares y peliculas HD a alta velocidad WiFi activado conecte, compartir y crear. Comparte rapida y facilmente fotos Nikon 1 de alta calidad o conectate en un mundo de aplicaciones fotograficas creativas a traves de tu dispositivo inteligente. Funcionamiento de pantalla tactil ultra sensible pantalla tactil electrostatica de 7,5 cm 3,0 pulgadas, 1037 K puntos te permite enfocar, disparar y ajustar la configuracion de teclas o previsualizar funciones creativas, simplemente pulsando la pantalla. Captura fotos de alta resolucion mientras filmes y ve peliculas HD grabadas a 120 fps en camara lenta extrema Longitud focal 1030 mm. Sientete libre de contribuir! Aprende como se procesan los datos de tus comentarios. El propietario de este portal, Camaras EVIL, participa en el Programa de Afiliados de Amazon EU, un programa para obtener comisiones por compras adscritas. Al continuar navegando por el sitio, acepta nuestro uso de cookies. OK Cookie and Privacy Settings We use cookies to let us know when you visit our websites, how you interact with us, to enrich your user experience, and to customize your relationship with our website. You can also change some of your preferences. Note that blocking some types of cookies may impact your experience on our websites and the services we are able to offer. You always can block or delete cookies by changing your browser settings and force blocking all cookies on this website. You are free to opt out any time or opt in for other cookies to get a better experience. If you refuse cookies we will remove all set cookies in our domain. Due to security reasons we are not able to show or modify cookies from other domains. You can check these in your browser security settings. We need 2 cookies to store this setting. <http://www.rh-arch.com/content/file/digitech-rp90-manual-castellano.xml>

- **manuales camaras nikon, manual camaras nikon, camaras manuales nikon, cameras manuales nikon cameras, cameras manuales nikon camera, cameras manuales nikon lens, cameras manuales nikon pro.**

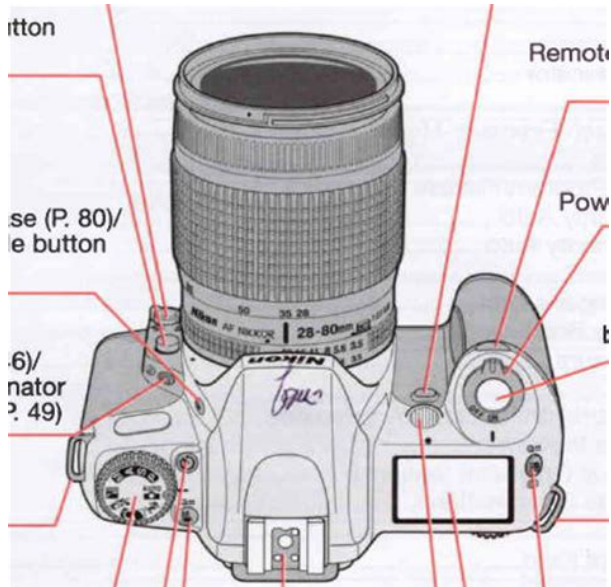

Otherwise you will be prompted again when opening a new browser window or new a tab. Since these providers may collect personal data like your IP address we allow you to block them here. Please be aware that this might heavily reduce the functionality and appearance of our site. Changes will take effect once you reload the page. Knowing the ins and outs of your camera settings can improve your photography tremendously. Your Information First Name required Last Name required Email required Country required United States Brazil Canada English Canada French Latin America Mexico Other By clicking Sign Up, you are opting to receive promotional, educational, ecommerce and product registration emails from Nikon Inc. You can update your preferences or unsubscribe any time. Detalles mas nitidos en altas luces y sombras DLighting Activo en peliculas e imagenes fijas El DLighting Activo de Nikon resalta los detalles donde hay muchas luces y sombras, los cuales suelen perderse. En particular, es efectivo al grabar sujetos con gran contraluz o en situaciones con luz solar directa. Formato RAW NRW Edicion y procesamiento posterior mas faciles La COOLPIX A1000 puede capturar imagenes RAW NRW sin comprimir. Deslice los dedos para revisar sus fotos y para ampliar. Boton de quitar zoom para sujetos lejanos A distancias de supertelefoto, puede perder de vista su sujeto. Pantalla Clear Color This innovative technology improves screen visibility for a more vivid, clear image when taking and sharing pictures. Reflections are minimized while contrast and power savings are improved. In select COOLPIX models. AF con Busqueda de Objetivo Ciertas camaras digitales COOLPIX utilizan la funcion AF con Busqueda de Objetivo que evalua instantaneamente el sujeto deseado y automaticamente ajusta la zona AF segun el tamano para asegurar la captura de imagenes con enfoque claro. [http://atomleasing.ru/media/digitech\\_rp90\\_manual\\_portugues.xml](http://atomleasing.ru/media/digitech_rp90_manual_portugues.xml)



Seguimiento del Sujeto Las camaras COOLPIX, y algunas reflex digitales en modo Live View, mantienen el enfoque sobre un sujeto en movimiento utilizando un sistema de deteccion de contraste que se basa en el principio de que los objetos enfocados de una escena muestran el contraste mas alto. WiFi Hace referencia a la tecnologia y la comunicacion inalambrica. En fotografia, es mas comun la transmision inalambrica de imagenes directamente desde una camara hacia un computador con el fin de alcanzar un flujo de trabajo mas rapido. Android, Google Play son marcas comerciales de Google Inc. Todas las marcas comerciales de Nikon son marcas comerciales de Nikon Corporation. El tamaño máximo de un archivo de película individual es de 4 GB. Si un archivo excede los 4 GB, incluso cuando graba por menos de 29 minutos, se divide en varios archivos y no se puede reproducir de forma continua. Incluidos Adaptador de Carga de CA EH73P Lo sentimos. Incluidos Cable USB UCE21 Lo sentimos. Incluidos Correa ANCP19 Lo sentimos. Cargador de batería MH65 Lo sentimos. Adaptador de Corriente Alterna EH62F Lo sentimos. Control Remoto Bluetooth MLL7 Lo sentimos. Compatible Con ViewNXi Lo sentimos. Por favor, intentalo de nuevo mas tarde.Intentalo de nuevo.Para salir de este carrusel, utiliza la tecla de acceso directo del encabezado para desplazarte al encabezado siguiente o anterior. Full content visible, double tap to read brief content. Intenta mas tarde hacer tu busqueda de nuevo.El set contiene 3 diferentes longitudes de tubo; 7 mm, 14 mm y 28 mm, que pueden ser utilizados individualmente o en cualquier combinacion para obtener el aumento deseado. Nota Estos son tubos de manual y no de comunicar funciones electronicas, tales como el enfoque o en auto control de exposicion, entre su cuerpo de la camara y lente. Ambos, enfoque manual y exposicion manual control debe ser utilizado.

Esta suave funda de lentes de diseño de precisión está diseñada para acomodarse a una amplia variedad de lentes más pequeñas hasta 5 pulgadas, que ofrece una gran cantidad de protección en una funda ligera, versátil, cómoda. Incluye un exterior de nylon impermeable, interior fully padded, cierre de cordón, y práctico para cinturón. Este kit de limpieza de 5 piezas contiene todo lo que necesitas para limpiar correctamente sus lentes, incluyendo, paños de limpieza de lente, pano de la lente, líquido de limpieza de lentes, cepillo para polvo soplador y algodón SWABS. Amazon calcula la calificación de estrellas de un producto utilizando un modelo de aprendizaje mecánico en lugar de un promedio de datos sin procesar. El modelo de aprendizaje mecanizado toma en cuenta factores que incluyen la edad de una reseña, los votos de ayuda de los clientes y si las opiniones pertenecen a compras verificadas. Only took 4 days ! New HostGator website hence the gator icon Any online donations always went to PayPal and their secure site will come up. Cosina, Yashica, At least once a week I get a Email stating I can make money by adding Pentax, Nikon, Canon, Chinon, Ricoh, Sears, Kodak, Cosina, Fujica. Miranda, Ansco, Agfa, Konica and other film cameras, flashes, winders, data backs, manuals and all the images from these instruction manuals. This library of information is only here for your information. If no link appears, I have yet If I can locate the manual and I have Any links outside of my site are noted. Use the icon on the specific manual page or go to the PayPal

Verified link This will allow me to buy new manuals, and pay to host this AD FREE site. Address accurate as of Jan, 2020 I do not take phone calls.Heres a list of non US sites that found my site useful. You must have JavaScript enabled in your browser to utilize the functionality of this website. You can simply remove the item from your cart. You have no obligation to purchase the product once you know the price.

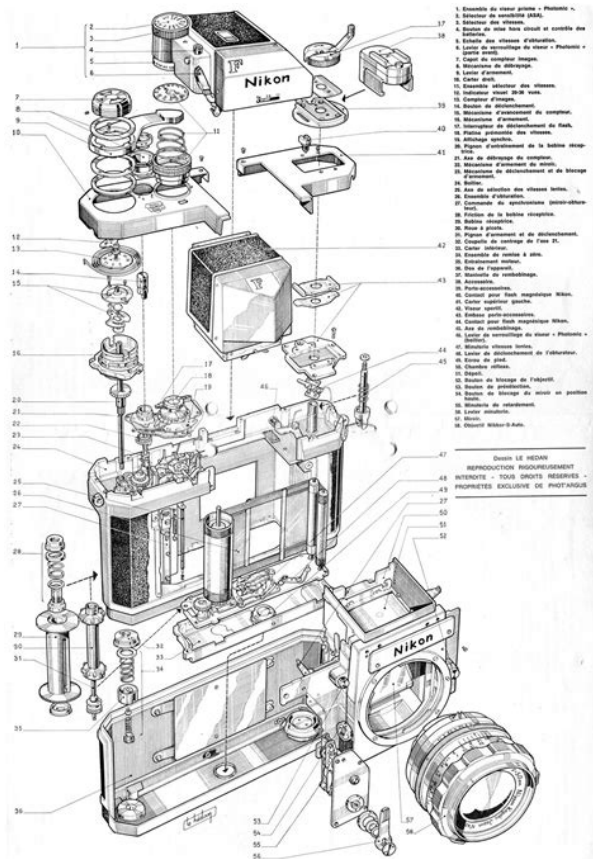

<https://formations.fondationmironroyer.com/en/node/8705>

You can simply remove the item from your cart. For people named Nikon, see Nikon disambiguation. Nikons main competitors in camera and lens manufacturing include Canon, Sony, Fujifilm, Panasonic, Pentax, and Olympus. During World War II the company operated thirty factories with 2,000 employees, manufacturing binoculars, lenses, bomb sights, and periscopes for the Japanese military. Duncan was working in Tokyo when the Korean War began. Duncan had met a young Japanese photographer, Jun Miki, who introduced Duncan to Nikon lenses. This would cause some early problems in Germany as Zeiss complained that Nikon violated its trademarked camera. Expeed is the brand Nikon uses for its image processors since 2007. Canon introduced a new type of lens-camera interface with its entirely electronic Canon EOS cameras and Canon EF lens mount in 1987. Launched September 1991 on board the Space Shuttle Discovery, mission STS48. The company also has a Coolpix line which grew as consumer digital photography became increasingly prevalent through the early 2000s. Nikon also never made any phones. The R10 and R8 SUPER ZOOM Super 8 models introduced in 1973 were the top of the line and last attempt for the amateur movie field. The cameras had a special gate and claw system to improve image steadiness and overcome a major drawback of Super 8 cartridge design. The R10 model has a high speed 10X macro zoom lens. The company constructed a factory in Ayuthaya north of Bangkok in Thailand in 1991. By the year 2000, it had 2,000 employees. Steady growth over the next few years and an increase of floor space from the original 19,400 square meters 208,827 square feet to 46,200 square

meters 497,300 square feet enabled the factory to produce a wider range of Nikon products. By 2004, it had more than 8,000 workers. In later production cycles, the cameras were double branded with a series name on the one and a sales name on the other hand.

<http://gvshaw.com/images/brookstone-park-it-manual.pdf>

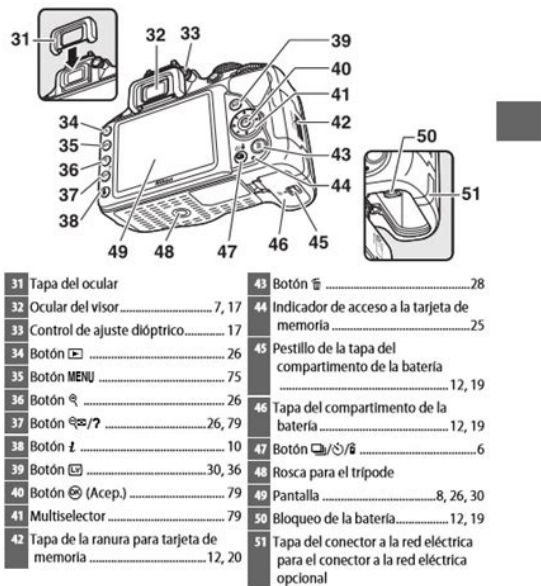

Sales names were for example ZoomTouch for cameras with a wide zoom range, LiteTouch for ultra compact models, FunTouch for easy to use cameras and SportTouch for splash water resistance. After the late 1990s, Nikon dropped the series names and continued only with the sales name. Nikons APScameras were all named Nuvis. The Fmount was first introduced on the Nikon F camera in 1959. Recent models include the SBR200, SB300, SB400, SB600, SB700, SB800, SB900, SB910, SB5000 and R1C1. Prior to the development of cool LED lighting this scanner used a halogen lamp hence the name Coolscan for the following models. The resolution of the following LED based Coolscan model didnt increase but the price was significantly lower. Colour depth, scan quality, imaging and hardware functionality as well as scanning speed was gradually improved with each following model. The final top of the line 35mm Coolscan LS5000 ED was a device capable of archiving greater numbers of slides; 50 framed slides or 40 images on film roll. It could scan all these in one batch using special adapters. A single maximum resolution scan was performed in no more than 20 seconds as long as no postprocessing was also performed. With the launch of the Coolscan 9000 ED Nikon introduced its most uptodate film scanner which, like the Minolta Dimage scanners were the only film scanners that, due to a special version of Digital ICE, were able to scan Kodachrome film reliably both dust and scratch free. In 1925 the microscope having revolving nosepiece and interchangeable objectives was produced. Significant growth for the microscopy division occurs over the next 50 years as Nikon pioneers development of polarising and stereo microscopes along with new products for measuring and inspection Metrology markets. These new products include devices targeted for industrial use such as optical comparators, autocollimators, profile projector and automated vision based systems.



Continued effort through the next three decades yield the release of products including the Optiphot and Labophot microscopes, Diaphot microscope, the Eclipse range of infinity optics, and finally the DS camera series and the Coolscope with the advent of digital sensors. With the acquisition of Metris in 2009 the Nikon Metrology division was born. Retrieved 20100205. Retrieved 20100205. The University of Texas at Austin. Archived from the original on 20071216. Retrieved 20100205. Retrieved 20100205. Retrieved 5 February 2010. Retrieved 20100205. Retrieved 20100205. Retrieved 20100205. Retrieved 30 December 2016. Nov 8, 2016. Retrieved 2 January 2017. Retrieved 2 January 2017. Archived from the original on 20100302. Retrieved 20100205. Retrieved 20100916. Nikon Corporation. August 28, 2017. Retrieved 20170528. Retrieved 20191017. Retrieved 20191017. Retrieved 30 December 2016. Archived from the original on May 2, 2015. Foods and beverages By using this site, you agree to the Terms of Use and Privacy Policy. Yo creo que las antiguas camaras de pelicula eran mucho mas autenticas y personales que cualquier smartphone o camara digital que podamos encontrar ahora en el mercado por muy comodas que sean. Los fotografos de "antes" dicen que la relacion que tenian con su camara era mucho mas intima. Nadie podar tocarla. Eso se traducia en fotos mucho mas personales y, sobre todo, en una estetica mucho mas original sin necesidad de filtros ni artificios. Para todos los amantes de las camaras analogicas ahi os dejo las 10 mejores que aun estan en el mercado y cuestan menos de 500 euros. El unico inconveniente es que practicamente no hay posibilidad de revelar el carrete por lo que os animo a que instaleis en casa vuestra propia "dark room experiencie". Os asombrara el resultado final. As the nearest avid photographer might tell you, there are plenty of reasons to use a high quality film camera over some digital counterpart.

Not only have the best 35mm film cameras provided some of the most iconic pictures of all time, but psychologically speaking they prompt a certain level of patience and craft that's almost immediately coopted by the freedom of digital photography. In other words, the best film cameras ask that you take your time, get to know your gear, and find your own aesthetic. Plus, there are a number of folks who will just tell you that film looks better, regardless of how far digital technology has come. If all

this has you itching for the dark room experience, then we say hang up that DSLR and grab one the 10 Best Traditional Film Cameras instead. After all, sometimes the best technology of today is the best technology of yesterday as well. Canon AE1 35mm Film Camera No es una mas, la camara de pelicula Canon AE1 de 35 mm es una historia viva. Fabricada en Japon a finales de los anos 70 y principios de los 80, fue la primera camara reflex de objetivo unico SLR equipada con un microprocesador. Entre eso y otras características notables como su lente intercambiable y el obturador del plano focal de tela horizontal del electroiman, la camara salio al mercado con fuerza y se vendio como rosquillas para ser una SLR. Hasta el dia de hoy, sigue siendo una hermosa pieza y es una de las mejores camaras de pelicula de alta calidad que puede encontrar para el rango de precio. More than just a piece of solid gadgetry, the Canon AE1 35mm Film Camera is living history. Made in Japan during the late 70s and early 80s, it was the first singlelens reflex SLR camera to come equipped with a microprocessor. Between that and other notable features like its interchangeable lens and electromagnet horizontal cloth focal plane shutter, the camera came roaring out the gates and sold in record numbers for an SLR. To this day, it remains a beautiful piece of equipment, and one of the best high quality film cameras you can find for the price range. Pentax K1000 Viva el Pentax K1000.

<http://www.1atlanticfunding.com/wp-content/plugins/formcraft/file-upload/server/content/files/162701fbcd477d---boss-dr-880-manual-portugues.pdf>

La camara de pelicula reflex de 35 mm fiable y asequible reino durante mas de veinte anos antes de su final en 1997. Se distingue del resto por su diseno vanguardista y porque la camara de pelicula superior no requiere una bateria para funcionar aunque si una bateria celular A76 para medir la luz. La camara aloja tres controles de disparo apertura, velocidad de obturacion y enfoque. Carga algo de pelicula, establece la velocidad y espera la toma perfecta. Esa es la belleza de la fotografia tradicional. Long live the Pentax K1000. The trusty and affordable 35mm SLR film camera reigned for just over twenty years before shuttering no pun intended in 1997. Distinguished by a completely unfettered design, the top film camera doesn't require a battery to operate though you will need to instal an A76 cell battery to use the light meter, and hosts just three shooting controls aperture, shutter speed and focus. Load up some film, set the speed, and wait for that perfect shot. That's the beauty of traditional photography. LeicaMA Type 127 Rangefinder Camera Aqui os presento la unica y verdadera LeicaMA. Como veis en la foto la camara tiene un cuerpo compacto totalmente metalico, de impresionante negro mate con acentos de laton cromado que te dara pasarte al mundo analogico en un pis pas. Al enfatizar los conceptos basicos, como el enfoque, la apertura y la velocidad de obturacion, la LeicaMA se convertira desde el primer momento en una de tus posesiones mas preciadas. El privilegio te costara, pero valdra cada centimo. Esta camara es, sin duda, una de las mejores camaras de pelicula que puedes encontrar. The one, the only LeicaMA Rangefinder Camera. Touting a compact, allmetal body of stunning matte black with chrome brass accents, the high quality film camera will have you straying from the digital path for good. The privilege will cost you, but it will be worth every penny. This is easily one of the best film cameras you can find.

Nikon F2 Photomic 35mm Film Camera Otro clasico retro. La Nikon F2 fue la ultima SLR profesional totalmente mecanica producida por la marca. Practicamente todo lo que se encuentra en la camara se controla manualmente, lo que invita a conocer mas de cerca todo el equipo. Ya sabes, como deberia ser. Another retro classic, the Nikon F2 was the last allmechanical professional SLR produced by the brand. Essentially everything on the camera is manually controlled, thereby inviting you to get up close and personal with your gear. You now, the way it should be. Leica M6 TTL Limitada a solo 3130 unidades en su produccion, la Leica M6 TTL es robusta, avanzada para su epoca, rara y extraordinaria. Esta camara de telemetro superior se une a la medicion de luz manual a traves de la lente TTL con flechas LED en el visor y un obturador mecanico suave. Como resultado se puede manipular la lente o el obturador para equilibrar los LED y asi lograr la exposicion ideal sin

preocuparse por los filtros o por un medidor externo. Limited to a mere 3130 units during its production run, the Leica M6 TTL is hefty, advanced for its time, rare and extraordinary. This top rangefinder camera joins through the lens TTL manual light metering with LED arrows in the viewfinder and a smooth mechanical shutter. As a result, you can tinker with the lens or shutter to balance the LEDs, achieving ideal exposure without concerning yourself with filters or an external meter. Olympus OM1 35mm Film Camera Completamente manual y maravillosa, la Olympus OM1 es una de mis preferidas. Es precisamente su estilo tan vintage de los 70 lo que la mantiene de rabiosa actualidad y por supuesto su sencillo y simple funcionamiento. Si estas buscando una camara analogica compacta, liviana y robusta que no te cueste un rinon tu busqueda finaliza aqui. Fully manual and beautifully affordable is the Olympus OM1. This vintage 70s stunner keeps it straightforward in function and clean in design.

If you're looking for a compact, lightweight, sturdy analog camera that won't set you back on rent, your search ends here. Canon Canonet QL17 GIII Film Camera Si lo que buscas es diseno retro con prestaciones aceptables la Canon Canonet QL17 GIII te encantara. Esta camara analogica de 35mm parece sacada directamente de la maquina del tiempo o de un museo y eso es, sin duda, parte de su encanto. If only the most retro design will suffice, accept nothing less than the Canonet QL17 GIII from Canon. The 35mm rangefinder camera looks like it hopped straight out of a time machine from the 1970s, and that's part of its charm. Nikon F6 AF 35mm SLR Film Camera La sexta generacion de la aclamada serie F, la Nikon F6, esta en el Top 10 de todas las camaras analogicas habidas y por haber. Esta brillante camara reflex de 35 mm se lanzo por primera vez en 2004 y desde entonces ha sido la preferida por los profesionales. Eso es gracias a una hoja de prestaciones practicamente infinita que incluye deteccion de fase TTL y tres medidores de exposicion incorporados. El resultado es una poderosa y versatil bestia de camara que ofrece la funcionalidad sin fin de lo digital, pero la calidad constante de la pelicula analogica. The sixth generation in the acclaimed Nikon F series, the Nikon F6 is accordingly top of the line. The brilliant 35mm SLR camera was first released in 2004 and has been a goto among professionals ever since. That's thanks to a virtually endless spec sheet, which includes TTL phase detection and three builtin exposure meters. The result is a powerful, versatile beast of a camera that delivers the endless functionality of digital, but the steadfast quality of film. Minolta X700 35mm SLR Film Camera Para los que pensais que las camaras manuales son ingeniosas en concepto pero un tanto laboriosas en la ejecucion, os recomiendo un rapido vistazo a la Minolta X700 de 35 mm.

Esta camara permite la configuracion automatica en la apertura o el obturador, lo que significa que no tienes que ajustar personalmente la camara para adaptarla a un cambio ambiental. Además, puedes programar la camara para que corresponda automaticamente a una velocidad de obturacion especifica con una apertura determinada. Si prefieres mantener el control total de cada detalle, la camara de pelicula de alta calidad tambien ofrece exposicion y enfoque manual. For those who think manual cameras are nifty in concept, but a little too laborious in execution, check out the Minolta X700 35mm SLR Film Camera. It allows for automatic setting on the aperture or shutter, meaning you don't have to personally adjust the camera to adapt to an environmental change. Furthermore, you can program the camera to automatically correspond a specific shutter speed with a given aperture. Of course, if you'd rather retain full control over every detail, the high quality film camera offers manual exposure and focus as well. Nikon FM2 SLR Manual Focus Film Camera Y para acabar la lista de las mejores camaras analogicas aqui teneis la Nikon FM2. Esta camara piensa, es agil, duradera, ligera, rapida y consistente; sin duda opciones a tener en cuenta a la hora de comprar una. Capping off our list of the best film cameras is the Nikon FM2. Think, nimble, durable, lightweight, fast and consistent, and you have a firm idea of what to expect from this manual gadget. Fotografia The Trendy Man Blog de tendencias, moda y lifestyle para hombres escrito por el periodista, blogger e influencer Miguel Biedma Just Me, Myself and I Madrid, Spain. Read our full review to see why its got the best autofocus system weve ever seen. August 18 68 ZTE to launch the

first smartphone with underdisplay front camera on September 1st mobile Aug 18, 2020 at 1829 After weve seen prototype designs from Xiaomi and Oppo, rival ZTE is now the first manufacturer to launch a device featuring the new technology.

17 Report Air Force One nearly collided with a drone, investigation launched Aug 18, 2020 at 1737 On Sunday night, witnesses on board Air Force One spotted a drone. August 17 42 New York City map makes it easy to find historical images of NYC from 1939 to 1941 Aug 17, 2020 at 1938 The map uses the NYC Municipal Archives digitized collection of historical photos captured by the NYC Tax Department. 58 Case dismissed against George Steinmetz, whose drone was confiscated for documenting mass burials Aug 17, 2020 at 1826 Back in April, awardwinning photographer George Steinmetz had his drone confiscated for documenting mass burials on Hart Island. Charges have since been dropped and his drone has been returned. 218 Video How to thoroughly clean and disinfect your camera video Aug 17, 2020 at 1611 Olympus Europe has partnered with photographer Fernando Marmolejo to create a video guide on how to keep your cameras and lenses clean and disinfected. 24 Adobe opens up free registration for its alldigital Adobe MAX 2020 conference Aug 17, 2020 at 1427 More than 250 speakers will take part in the event, including Annie Leibovitz, Tyler the Creator, Ava DuVernay, Keanu Reeves and others. The conference is scheduled for October 1921. Exploring the Alvord Desert with Andy Maser and the DJI Mavic Air 2 Sponsored Aug 17, 2020 at 1400 Join filmmaker Andy Maser and drone pilot Alex Emberlin as they use the new DJI Mavic Air 2 to explore the beautiful Alvord Desert in Oregon. 149 Nikon AFS Nikkor 120300mm F2.8E FL ED SR VR sample gallery sample gallery Aug 17, 2020 at 1300 The Nikkor 120300mm F2.8 has all the trappings of a prograde lens its unapologetically heavy, offers weather sealing and sports an alphabet soup of special lens elements and coatings in its name. Take a look at our samples. Weve been shooting with a final copy to see how it looks for everything from portraits to street photography and landscapes. August 15 139 DPReview TV Sigma 85mm F1.

4 DG DN Art review video Aug 15, 2020 at 0700 Sigma has been cranking out some fantastic lenses lately, and the new 85mm F1.4 DG DN Art joins the club. Find out why we like this fast, compact lens. Includes updated sample gallery. August 14 29 Hasselblad adds iPhone connectivity to its Phocus Mobile 2 application mobile Aug 14, 2020 at 2037 Phocus Mobile 2 has allowed Hasselblad mirrorless photographers to remotely control, process and share their images on iPad for over a year. With the latest update to Phocus Mobile 2, photographers can now perform many of these same functions on an iPhone. Inspired by photographers like Dorothea Lange and Francesca Woodman, Roper wanted a safe way to capture portraits reflective of the challenging times we are living in. He passed away in his Portland, Oregon home August 11, 2020. 191 Opinion Businesses, especially corporations, should pay to use your photos Aug 13, 2020 at 1300 Have you ever been approached through social media, or even your own website, by a business or corporation asking for permission to use one of your photos. August 12 177 Open source Raw processor Darktable gets substantial 3.2 update Aug 12, 2020 at 2009 Open source software such as darktable is a free alternative to expensive standalone and subscriptionbased photo editing software. In its latest release, darktable version 3.2 includes many new features and performance improvements. Initial results are positive we measured excellent, sub10ms rolling shutter rates, and we can confirm that the camera uses a dual gain sensor.

93 Hasselblad 907X 50C camera and accessories now available camera news Aug 12, 2020 at 1122 After a wait of over a year since the camera was first shown, the standard production version of the 907X is finally available, along with the new hand grip and optical viewfinder August 11 107 Canon releases firmware updates for the EOS R and 7 RF lenses Aug 11, 2020 at 1818 The firmware updates add support for new lenses, teleconverters and battery pack for the EOS R, and bring improved IS functionality to the EOS R5 and R6 cameras when used with IScapable RF lenses. 112 Xiaomi Mi 10 Ultra comes with 120mm optical tele, 120Hz display and more mobile Aug 11, 2020 at

1721 To mark the occasion of its 10th anniversary Xiaomi has launched the Mi 10 Ultra topend smartphone which with an optical focal length range from 12 to 120mm. 17 Slideshow 2020 Underwater Tour Awards Winners Aug 11, 2020 at 1643 The winners of the inaugural Underwater Tour Awards were recently announced. It offers letterbox aspect ratios as wide as 2.351, and it carries on the principles of being compact, light and affordable. August 10 114 Breakthrough Photography announces more than 20 dropin filters for Canons EFRF adapter Aug 10, 2020 at 1836 Breakthrough Photography, makers of many excellent filters, has announced the first thirdparty filters for Canons popular EFRF adapter with dropin filter slot. New filters include various circular polarizing, neutral density and specialty filters. Take a look at what it can do. 102 Zenit teases upcoming 60mm F2.8 macro, 58mm F1.9 and 35mm F2 lenses lens news Aug 10, 2020 at 1244 Aside from basic specifications, not much information is shared by Zenit, but the press releases suggest we will find out more come October 2020. August 9 422 Interview Photographer Cath Simard talks about developing your own personal style Aug 9, 2020 at 1300 Cath Simard makes a living shooting for major brands and teaching others her techniques at workshops around the globe.

<http://www.raumboerse-luzern.ch/mieten/3tk2828-manual>